



DATA SHEET



LIFT100

1. Datasheet

1.1. Lift100

General Properties		Minimum	Typical	Maximum	Unit
Allowed torque between the Lift100 and the robot	Static (Lift100 is not moving)	-	-	3400	[Nm]
	Dynamic (Lift100 is moving)	-	-	1900	[Nm]
Payload		0 0	- -	100 220	[kg] [lb]
Height above floor		730 28.74	- -	1630 64.17	[mm] [inch]
Stroke of the Lift100		0 0	- -	900 35.43	[mm] [inch]
Lift100 speed		10 0.34	- -	100 3.39	[mm/s] [in/s]
Positioning accuracy *		- -	+/- 3 +/- 0.12	- -	[mm] [inch]
Positioning repeatability *		- -	+/- 0.5 +/- 0.02	- -	[mm] [inch]
Noise level **		- -	- -	75 78	[dB(A)] _{Leq} [dB(A)] _{Max}
Weight		86 189.6			[kg] [lb]
Dimensions [L x W x D]		730 x 325 x 492 28.74 x 12.8 x 19.37	- -	1630 x 325 x 492 64.17 x 12.8 x 19.37	[mm] [inch]
Storage temperature		0 32	- -	60 140	[°C] [°F]
IP Classification		IP54			

* Along the driven axis.

** For more information, see the **Noise level** section.

Operating Conditions	Minimum	Typical	Maximum	Unit
Power supply	90	-	264	[V]
Current consumption	0	-	10.2	[A]
Frequency	47	-	63	[Hz]

Operating Conditions	Minimum	Typical	Maximum	Unit
Operating temperature	0	-	50	[°C]
	32	-	122	[°F]
Relative humidity (non-condensing)	0	-	95	[%]
Calculated operation life	1 000 000	-	-	[cycles]

Interface for Mounting an Energy Chain

The Lift100 has been designed with a mechanical interface to mount an energy chain. The brackets for the energy chain can be mounted on the screw holes M5 and M8 shown below. For the bottom holes (M8), the plate can be removed to install the energy chain bracket.

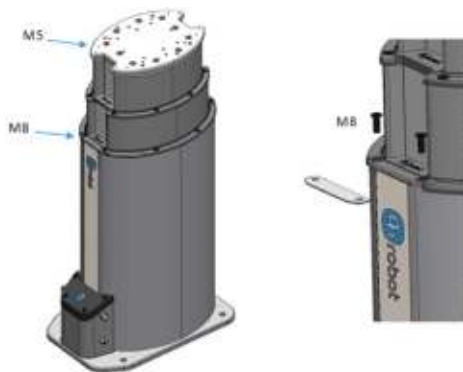

Noise Level

The noise level of the Lift100 depends on the speed and the stroke position. Higher speed and stroke increase the noise. The noise level also depends on the surroundings and other equipment.

To measure the Lift100's noise level, a test has been carried out by an external company.

The test setup was the following:

- The test took place in a normal indoor production area.
- The Lift100 was bolted to the floor and had a 74 kg robot mounted.
- The test ran 4 cycles, full stroke up and down, 100 % speed and with no pause in between the cycles.
- The noise measurement equipment was located in 2 m distance away from the Lift100.

The test concludes that the average measured noise level was 75 dB(A)_{Leq} and the maximum noise level was 78 dB(A)_{Max} which is below the maximum allowed noise level of (80 dB(A)).

The Lift100 will run about 5-15 % of the time in a normal palletizing application, which means that the average noise level will decrease significantly.

1.2. Lift100

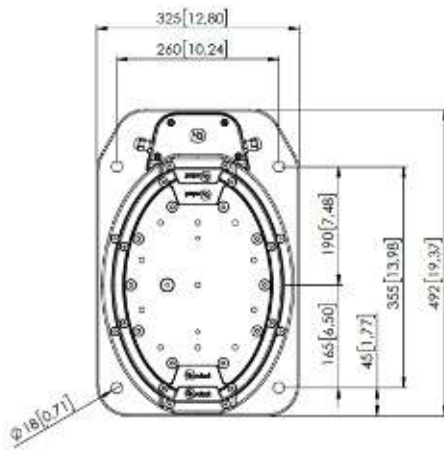
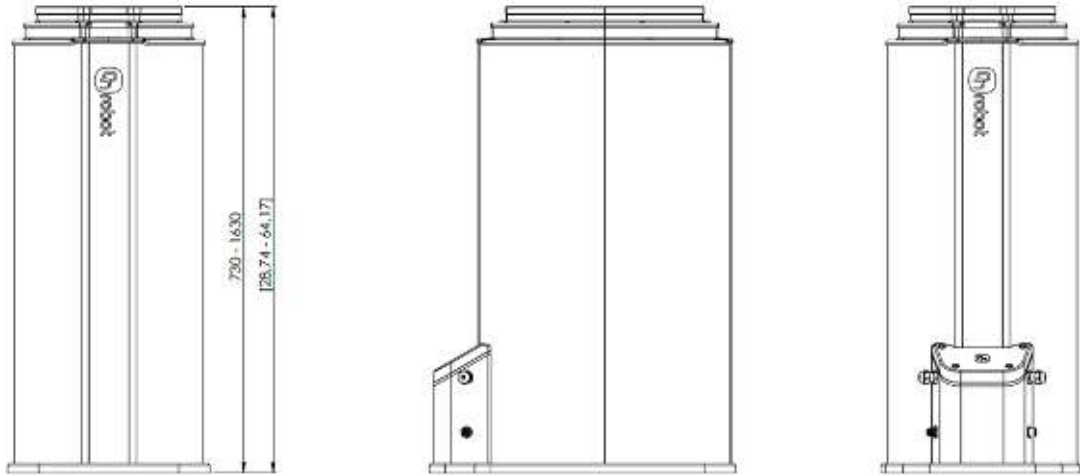

All dimensions are in mm and [inches].