



## DATA SHEET



# VGP20

# 1. Datasheet

## 1.1. VGP20

General Properties	Minimum	Typical	Maximum	Unit
Vacuum	5 % -0.05 1.5	- - -	60 % -0.607 17.95	[Vacuum] [Bar] [inHg]
Air flow in total	0	-	48	[L/min]
Air flow on each channel	0	-	12	[L/min]
Payload (with default attachments)	- -	10 <sup>(1)</sup> 22.04	20 <sup>(2)</sup> 44.09	[kg] [lb]
Vacuum cups	1	16	16	[pcs.]
Gripping time (measured with vacuum target 40%)	-	0.25 <sup>(3)</sup>	-	[s]
Releasing time	-	0.4 <sup>(3)</sup>	-	[s]
Noise level <sup>(4)</sup>	-	67	71	[dB(A)]
Vacuum pump	Integrated, electric BLDC			
Dust filters	Integrated 50µm, field replaceable			
IP Classification	IP54			
Dimensions	264 x 184 x 92 10.39 x 7.24 x 3.62			[mm] [inch]
Weight	2.55 5.62			[kg] [lb]

(1) Cardboard is recommended up to 10 kg.

(2) 20 kg payload can be achieved with low accelerations (0.2G added to 1G; 1G = gravity = 9.82 m/s<sup>2</sup>). Other conditions may apply.

(3) The gripping time can be shortened with smaller or less suction cups. The release time depends on the payload. With high payload, you can achieve fast release time.

(4) For more information, see **Noise Level** section.

Operating Conditions	Minimum	Typical	Maximum	Unit
Power supply	20.4	24	28.8	[V]
Current consumption	50	2500	4500	[mA]
Operating temperature	0 32	- -	50 122	[°C] [°F]
Relative humidity (non-condensing)	0	-	95	[%]
Calculated operation life	25 000	-	-	[hours]

### Find Maximum Vacuum Based on the Workpiece

Different workpiece types allow for different vacuum due to the air leaking. For more information about vacuum and air flow/air leaking, see sections **Vacuum** and **Airflow**.

To find the maximum vacuum for your workpiece in the fastest and easiest way, use one of the graphical user interfaces like the WebClient/Monitor and Control and follow these steps:

1. Set the target vacuum to 60% and grip.
2. Read the current vacuum (this indicates the maximum target vacuum that could work).
3. Set the new target vacuum as the current vacuum achieved before, subtract 3-5 % (kPa) and grip.
4. If the vacuum is achieved, this is the recommended vacuum for your workpiece. If the vacuum is not achieved, try to decrease it a bit more and check it again.

If your robot does not have a graphical user interface and you do not have access to the WebClient, try the following steps:

1. Set the target vacuum to 20% and check whether the gripper can achieve it.
2. If it is successful, set the target vacuum to 30% and check whether the gripper can achieve it.
3. If it is successful, continue increasing in steps of 10 until the vacuum is not achieved.
4. When the vacuum is not achieved, step 5% down until the vacuum is achieved.

The following graph provides an overview of the vacuums that can be achieved depending on the workpiece porousness.

### Porousness vs Vacuum graph

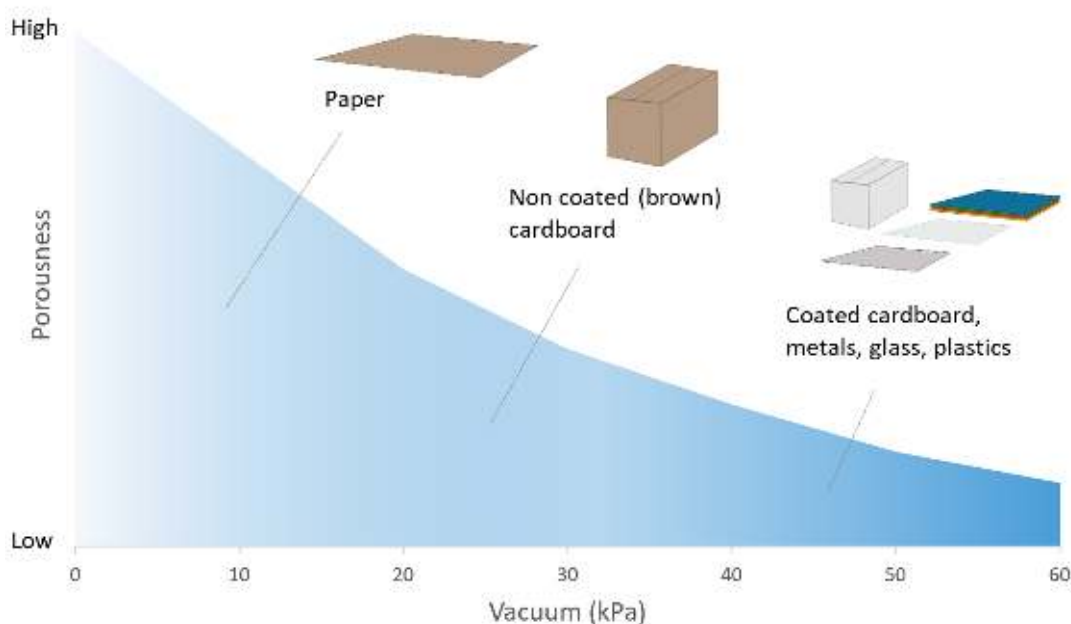

### Payload

The lifting capacity of the gripper depends primarily on the following parameters:

- Vacuum cups
- Vacuum
- Air flow

### Vacuum Cups

The gripper comes with common 40 mm silicone vacuum cups (see table below) which are good for hard and flat surfaces, but not good for uneven surfaces and it might leave microscopic traces of silicone on the workpiece which can cause issues with some types of painting processes afterwards.

Image	External Diameter [mm]	Internal Diameter [mm]	Gripping Area [mm <sup>2</sup> ]
	40	24	450

For non-porous materials, the OnRobot suction cups are highly recommended. Some of the most common non-porous materials are listed below:

- Composites
- Glass
- High density cardboard
- High density paper
- Metals
- Plastic
- Porous materials with a sealed surface
- Varnished wood

In an ideal case, working with non-porous material workpieces where there are no air flow going through the workpiece, the table below shows the number of cups and the cup size needed depending on the payload (workpiece mass) and the vacuum used.

**Number of Cups needed for non-porous materials depending on payload and vacuum :**

Payload (kg)	 40 mm		
	Vacuum (kPa)		
	20	40	60
1	2	1	1
2	4	2	2
4	7	4	3
5	9	5	3
6	10	5	4
8	14	7	5
10	16	9	6
12	-	9	6
15	-	12	8

20	-	16	11
----	---	----	----

The table above is created with the following formula that equalizes the lifting force with the payload considering 1.5G of acceleration.

$$\text{Amount}_{\text{Cups}} * \text{Area}_{\text{Cup}}[\text{mm}] = 14700 \frac{\text{Payload} [\text{kg}]}{\text{Vacuum} [\text{kPa}]}$$

It is often a good idea to use more vacuum cups than needed, to accommodate for vibrations, leaks and other unexpected conditions. However, the more vacuum cups, the more air leakage (air flow) is expected and the more air is moved in a grip resulting in longer gripping times.

When using porous materials, the vacuum that can be achieved by using the OnRobot suction cups will depend on the material itself and will be between the range stated in the specifications. Some of the most common porous materials are listed below:

- Fabrics
- Foam
- Foam with open cells
- Low density cardboard
- Low density paper
- Perforated materials
- Untreated wood

See the table below with general recommendations, in case other suction cups are needed for specific materials.

Workpiece surface	Vacuum cup shape	Vacuum cup material
Hard and flat	Normal or dual lip	Silicone or NBR
Soft plastic or plastic bag	Special plastic bag type	Special plastic bag type
Hard but curved or uneven	Thin dual lip	Silicone or soft NBR
To be painted afterwards	Any type	NBR only
Varying heights	1.5 or more bevels	Any type



**NOTE:**

It is recommended to consult a vacuum cup specialist to find the optimal vacuum cup where the standard types are insufficient.

**Suction Cups for Foil and Bags Ø25**

This suction cup improves the vacuum gripper's ability to pick and place workpieces with surface of foil, thin paper, and plastic bags during irregular and angular arm movement.

	 25 mm							
<b>Number of Cups</b>	<b>1</b>	<b>2</b>	<b>3</b>	<b>4</b>	<b>5</b>	<b>6</b>	<b>7</b>	<b>8</b>
<b>Surface</b>	<b>kg</b>							
Foil	0.83	1.07	1.43	1.57	1.79	2.03	2.27	2.51
Thin paper	1.08	1.71	2.23	3.21	3.74	4.37	5	5.63
Foil - round shape	1.28	2.32	3.32	4.25	5.44	6.48	7.52	8.56
Plastic bag	0.32	0.54	0.63	0.74	0.94	1.09	1.25	1.405

The vacuum cup is silicone rubber compliant with the USA Food and Drug Administration (FDA).

Using this vacuum cup reduces the wrinkles made on thin workpieces (film, vinyl, and so on)

during absorption: 

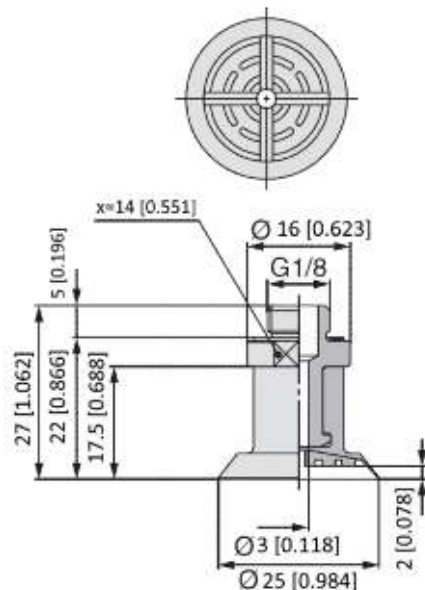

This vacuum cup is an accessory and need to be purchased separately. To purchase the vacuum cup, contact the vendor from where the VGx gripper has been purchased.

- Suction Cups for foil and bags Ø25 - PN 105922

## Vacuum

Vacuum is defined as the percentage of absolute vacuum achieved relative to atmospheric pressure, i.e.:

% vacuum	Bar	kPa	inHg	Typically used for
0%	0.00rel. 1.01 abs.	0.00rel. 101.3 abs.	0.0rel. 29.9 abs.	No vacuum / No lifting capacity
20%	0.20rel. 0.81 abs.	20.3rel. 81.1 abs.	6.0rel. 23.9 abs.	Cardboard and thin plastics
40%	0.41rel. 0.61 abs.	40.5rel. 60.8 abs.	12.0rel. 18.0 abs.	Light workpieces and long suction cup life span
60%	0.61rel. 0.41 abs.	60.8rel. 40.5 abs.	18.0rel. 12.0 abs.	Heavy workpieces and strongly secured grips

The vacuum in kPa setting is the target vacuum. The pump will run at full speed until the target vacuum is achieved, and then run at a lower speed necessary to maintain the target vacuum.

The pressure in the atmosphere varies with weather, temperature and altitude. The gripper automatically compensates for altitudes up to 2 km, where the pressure is about 80% of sea level.

## Airflow

Airflow is the amount of air that must be pumped to maintain the target vacuum. A completely tight system will not have any airflow, whereas real life applications have some smaller air leakages from two different sources:

- Leaking vacuum cup lips
- Leaking workpieces

The smallest leak under a vacuum cup can be hard to find (see picture below).

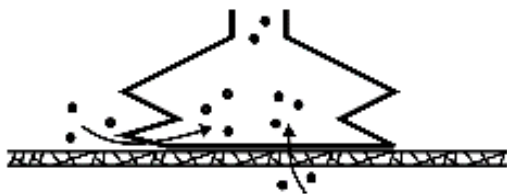

Leaking workpieces can be even harder to identify. Things that look completely tight might not be tight at all. A typical example is coarse cardboard boxes. The thin outer layer is often requiring a lot of airflow to create a pressure difference over it (see figure below).



Be aware of the following:

- Pay extra attention to leakages, e.g. vacuum cup shape and surface roughness.
- When gripping an object with high leakage, be sure to use as many of the channels A, B, C, and D as possible.

The following graph shows the airflow capability of the gripper.



**NOTE:**

The airflow depends on the number of used channels.

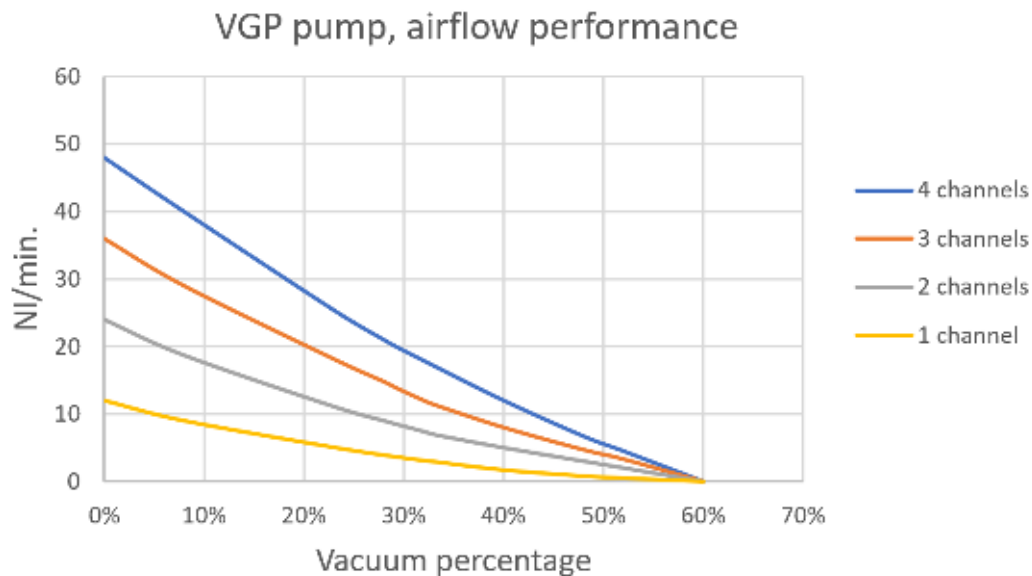

**NOTE:**

The easiest way to check if a cardboard box is sufficiently tight is simply to test it using the gripper.

A high vacuum percentage setting does not give a higher lifting capacity on corrugated cardboard. In fact, a lower setting is recommended, e.g. 20%.

A low vacuum setting results in less air flow and less friction below the vacuum cups. This means that the filters and the vacuum cups will last longer.

### 4 Channels

The VGP20 has 16 holes to use fittings with vacuum cups or blinding screws as needed. It also has lines which show the holes that are communicated together. This is useful when using the channels independently for vacuum.



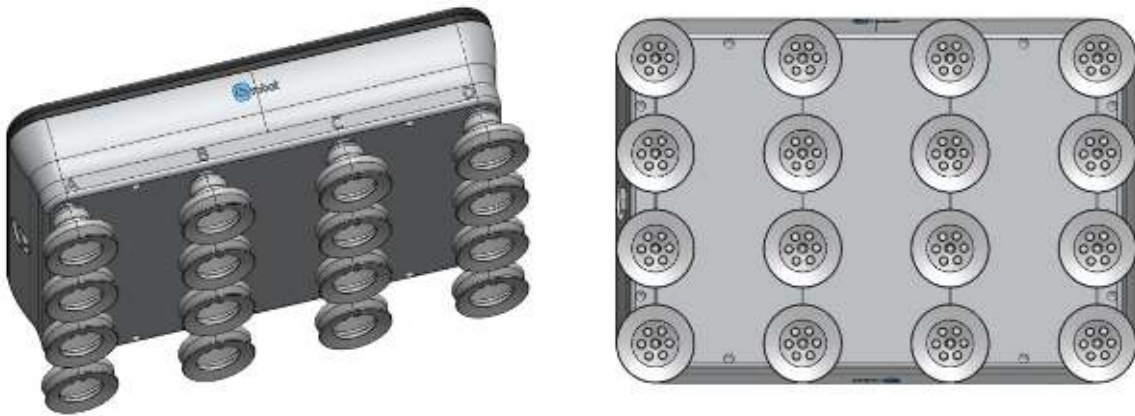

## Fittings and Blind Screws

It is possible to change the suction cups simply by pulling them off the fittings. Stretch the silicon to one of the sides and then pull the suction cup out.

Unused holes can be blinded using a blind screw, and each fitting can be changed to a different type to match the desired suction cup. The fittings and the blinding screws are mounted or dismounted by screwing (2 Nm tightening torque) or unscrewing them with the provided 3 mm hex key.

### Fittings



### Blind



The thread size is the commonly used G1/8"; allowing for standard fittings, blinders, and extenders to be fitted directly to the gripper.

## Remove Pump Exhaust

It is possible to lead the pump exhaust air away from the gripper. By removing the silencer on the side of the gripper, a G1/8 thread is available for a fitting and a tube to guide away the exhaust.



## Customize the Gripper

You can mount any customized equipment needed by using the available M6 threads on the bottom surface of the gripper.

Examples of a customized gripper:

- A plate is mounted to the gripper by the M6 holes in the cabinet. The plate thickness has to be at least 12 mm to fit the suction cup and the fitting.
- The plate has 8 G1/8 threads through the plate for the suction cups. The existing suction cups including fittings can then be used.



- G1/8 fittings can be used directly above the suction cups (this is not included).
- Same fitting can be used on the gripper and tubes can then be mounted in between.
- To get optimum lifting capacity, the suction cups must be divided equally for each channel on the gripper.

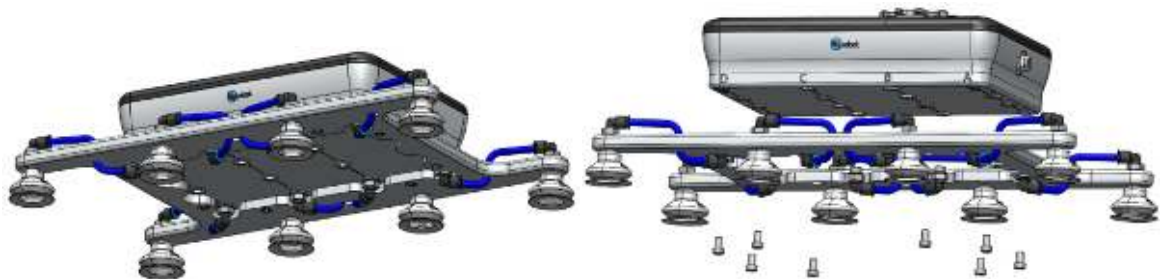

## Noise Level

The noise level of the gripper depends on the workpiece's surface and geometry, and more specifically on the leakage of the surface. It also depends on the surroundings and other equipment.

To measure the VGP20's noise level, a test has been carried out by an external company.

The test setup was the following:

- The test took place on a normal indoor production area.
- They used 4 different uncoated and 1 coated coarse cardboard as workpiece.
- The test run 4 cycles combining grips, robot moving holding the workpiece for 8 seconds, robot moving without the workpiece for 7 seconds, and releases.
- The noise measurement equipment was located 1 m distance from the robot arm.

The test concludes that the average measured noise level for the worst box was 71 dB(A) and the average noise for the 5 boxes was 67 dB(A) which is far below the maximum allowed noise level (80 dB(A)). Therefore, similar setups will not cause hearing damage on people remaining close to the VGP20.

Using a more dense uncoated cardboard as workpiece will significantly drop the noise level.

## 1.2. VGP20

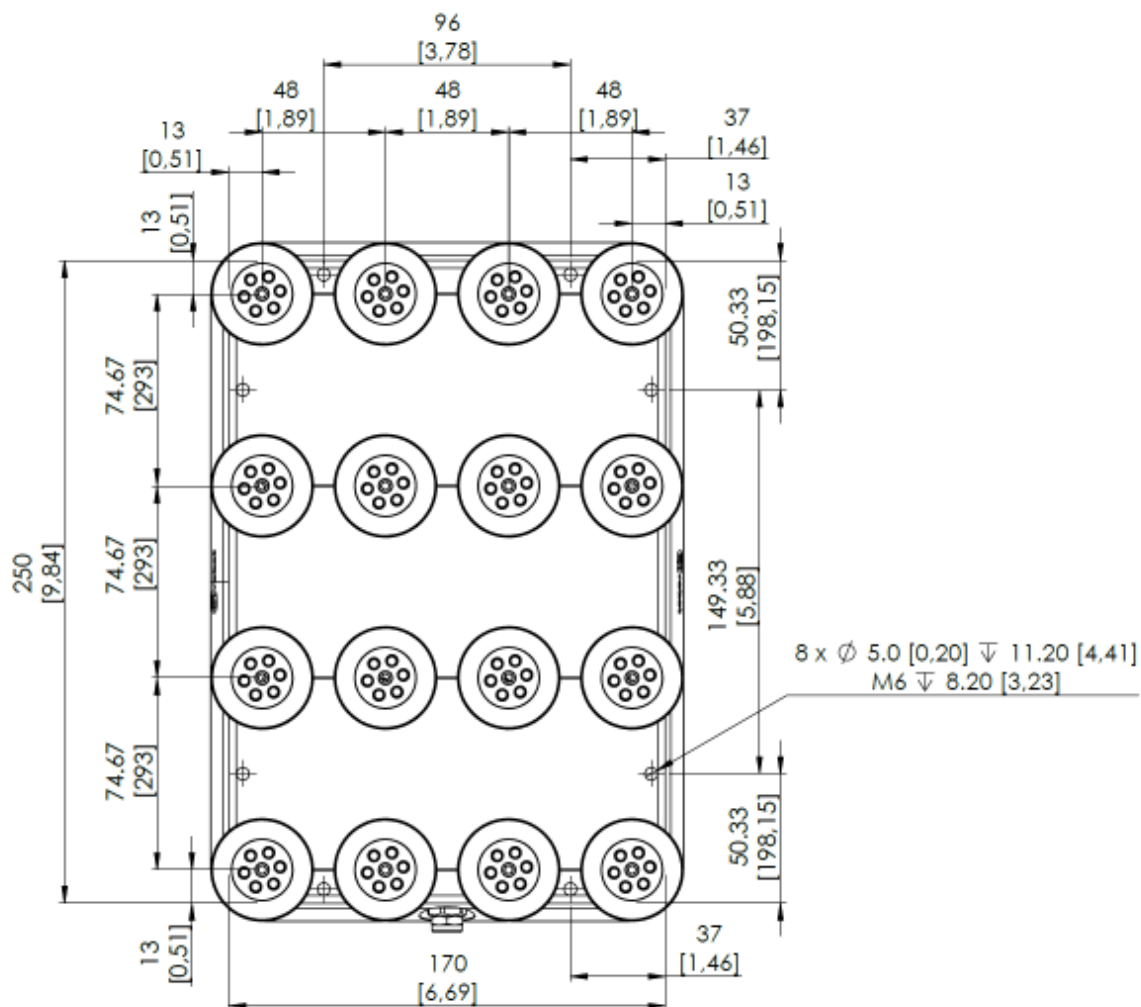

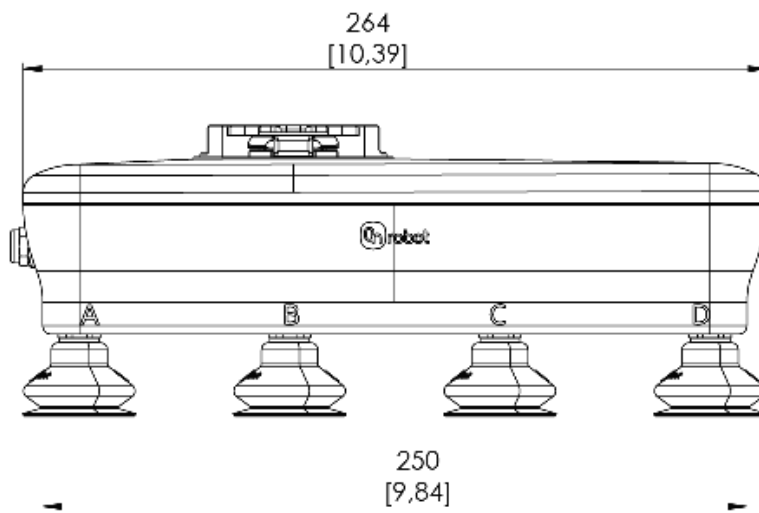
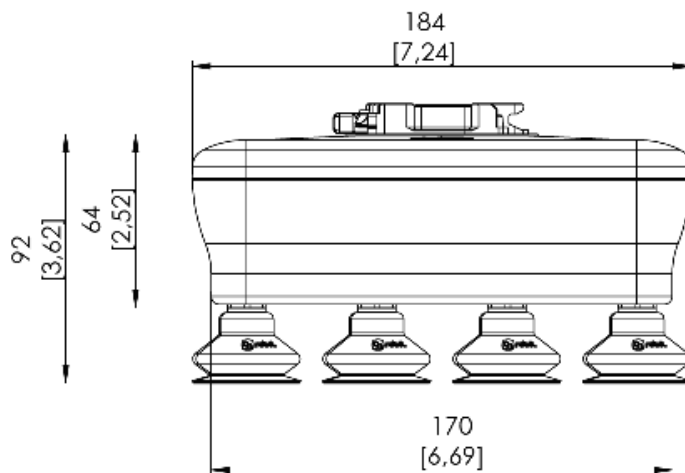

All dimensions are in mm and [inches].